

TOGGLE SWITCH SEALING BOOTS WITH INTEGRAL IQ™ MOUNTING NUT*



THE IQ CONCENTRO-NUT™ MOUNTS OVER THE SWITCH'S FRONT PANEL MOUNTING-NUT

- Ideal protection against unforgiving environmental hazards — prolongs switch reliability
- Ideal for speedy retrofitting of booted and non-booted switches
- Ideal for easy original equipment assembling
- Ideal for meeting aesthetic requirements that call for smooth exterior surface around mounting nut
- Ideal color solutions for matching boot color to exact panel color, or for defining specific control function on request. Standard color choices are gray and black.



INSTALLS QUICKLY

The APM HEXSEAL IQ Switch Sealing Boot is designed for applications where it is preferable to retain the original switch's front-panel mounting nut. This version is made possible by the incorporation of a newly designed bonded concentric mounting nut that features an internal cavity configuration allowing the integral CONCENTRO-NUT to sit on and wrap itself around the existing original switch front panel nut. This enables the two nuts to work in concert when tightened. The IQ Switch Sealing Boot mounting design permits an easy and speedy retrofit, or new OEM installation. The use of the IQ Sealing Boot prevents any switch disturbance; for example, the undesirable rotation of the switch body and possible stress on its connections.

No special tools or O-Rings, washers or adhesives are required. The IQ Switch Sealing Boot design also features a patented flange sealing-rib that fully contacts the front-panel surface, creating a vacuum-seal that protects the mounting hole from gas or liquid seepage contamination. In addition to standard black or gray, any color can be specified to match any panel or to define a control function.



*Patent Pending Made in USA

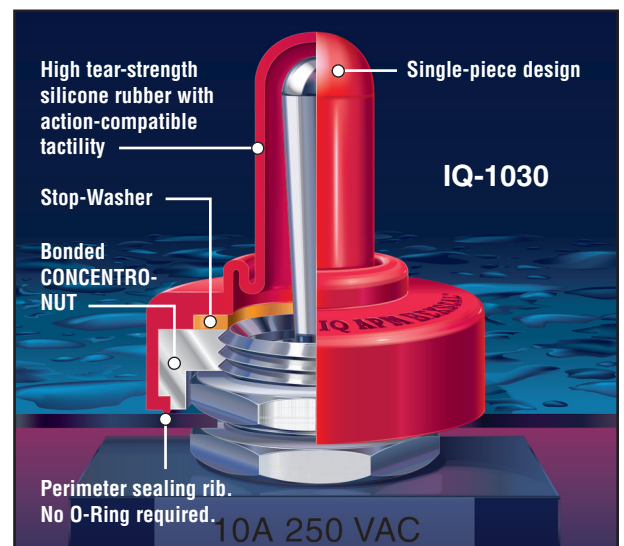

SPECIFICATIONS

- Sheath Material:** Silicone rubber conforms to A-A-59588, Class 3B, Grade 60 (unless otherwise specified)
- Mounting Nut (CONCENTRO-NUT) Material:** Aluminum
- Stop Nut Material:** Brass
- Temperature Range:** -94°F to +400°F (-70°C to +204°C)
- Pressure Range:** Exceeds 15 psi internal and 1,500 psi external
- Operational Life:** 50,000 actuations (minimum)
- Shelf Life:** Excess of 25 years
- Enclosure Protection:** IEC 60529 IP 66/68 Rating
- Resistant To:** Salt spray, sunlight, ozone, weather, ice, sand, dirt, fungus, most acids, solvents and lubricating oils
- Military Specs:** Meets MIL-B-5423
- Agency Recognition:** UL Qualification pending
- Installation:** Mounts over existing toggle switch actuator. Tighten approximately three turns.

HOW TO ORDER

- Specify APM Boot part number.
- Example: IQ-1030-(add color code letter here) G=Gray, B=Black
- Note: For special colors add PMS or other color specification. Consult factory.

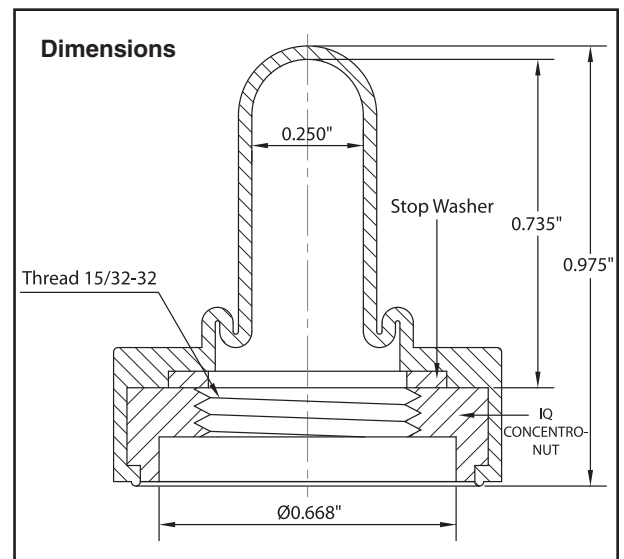

44 Honeck Street, Englewood NJ 07631
Tel: (201) 569-5700 • Toll Free: (800) 498-9034
Fax: (201) 569-4106

www.apmhxseal.com • Email: info@apmhxseal.com

APM HEXSEAL®

IQ SWITCH SEALS. IT'S A NO-BRAINER.